

Installation and user manual for

Local Extinguishing System

LES-RACK



Type designation: LES-RACK-M (Master), LES-RACK-S (Slave)

This manual describes procedures for installation, commissioning, operation and maintenance of extinguishing system with clean gas **LES-RACK** manufactured by company **CONTEG spol. s r.o.** The system may be used only for described applications and in strict compliance with instructions contained in this manual. Please read the manual carefully and keep it in safe place for future reference.

INDEX

I. GENERAL	4
I.1 USE	4
I.2 OPERATING CONDITIONS	4
I.3 SYSTEM DESCRIPTION	4
I.4 SYSTEM FUNCTIONALITY DESCRIPTION	5
I.5 GENERAL SAFETY INFORMATION	5
II. TECHNICAL SPECIFICATIONS	6
II.6 EXTINGUISHING SYSTEM TYPE VERSIONS	6
II.7 MAIN TECHNICAL PARAMETERS	7
II.8 DESIGN	7
II.9 MATERIAL	8
II.10 SURFACE FINISH	8
II.11 EXTINGUISHING UNIT	8
II.12 CONTROL UNIT	9
II.13 COMMUNICATION, REMOTE ACCESS AND HISTORY LOG	9
II.14 DETECTION ELEMENTS	9
II.15 POWER SUPPLY SOURCE	10
II.16 EXTINGUISHING AGENT	11
II.17 MARKING	11
III. REQUIREMENTS FOR PROTECTED EQUIPMENT	12
III.18 CLASSIFICATION OF PROTECTED SPACE, FIRE SAFETY	12
III.19 REQUIREMENTS FOR PROTECTED EQUIPMENT	12
IV. INSTALLATION	13
IV.20 GENERAL PROVISIONS	13
IV.21 SAFETY PROVISIONS	13
IV.22 SYSTEM INSTALLATION	13
IV.23 COMMISSIONING	13
IV.24 SYSTEM MAINS POWER SUPPLY	13
IV.25 SWITCHING OFF THE SYSTEM	13
IV.26 INSTALLATION OF CABLES	14
IV.27 INSTALLATION OF EXTERNAL COMPONENTS	14
IV.28 CONNECTION OF EXTERNAL INPUT AND OUTPUT DEVICES	14
V. CHECKS AND COMMISSIONING	16
V.29 LINE TESTING	16
V.30 CHECK OF THE DEVICES' FIXED POSITION	16
V.31 SYSTEM FUNCTIONALITY CHECK	17
V.32 CHECK OF DETECTION ELEMENTS	17
VI. OPERATION	17
VI.33 GENERAL REQUIREMENTS	17
VI.34 LES-RACK-M – OVERVIEW OF STATUS LEDs AND CONTROL ELEMENTS	18
VI.35 LES-RACK-S – OVERVIEW OF STATUS LEDs AND CONTROL ELEMENTS	19
VI.36 DESCRIPTION OF LES-RACK CONTROL ELEMENTS	20
VII. MAINTENANCE	21
VII.37 GENERAL PROVISIONS	21
VII.38 CHECKS PERFORMED BY USER	21
VII.39 CHECKS OF THE PROTECTED SPACE	22

VII.40	CHECKS PERFORMED BY SERVICE ORGANIZATION	22
VII.41	CHECKS AND SERVICE VIA SERIAL INTERFACES	23
VII.42	LIST OF ACCESSORIES AND SPARE PARTS	23
VIII.	ENVIRONMENTAL ASPECTS.....	24
VIII.43	SYSTEM'S LIFE-CYCLE	24
VIII.44	ENVIRONMENTAL IMPACT	24
VIII.45	MATERIAL SAFETY DATA SHEET – EXTINGUISHING AGENT HFC-236FA	24
IX.	WARRANTY.....	27
IX.46	WARRANTY TERMS AND CONDITIONS	27
IX.47	INTELLECTUAL PROPERTY	27
IX.48	STATEMENT OF COMPLIANCE.....	29
IX.49	CERTIFICATE OF WARRANTY	30

I. GENERAL

I.1 Use

LES-RACK is a self-contained, fully automatic detection and fire protection system. Designed for installation in 19" rack cabinets and bigger, it offers very efficient and effective solution for servers, telecommunication and control racks/cabinets. System **LES-RACK-M** consists of fully equipped automatic system of fire detection, control, evaluation, communication and extinguishing unit. Larger-sized server racks and adjacent cabinet units may be protected by additional auxiliary units **LES-RACK-S** consisting only of detection elements, communication and fire extinguishing unit. Slave units must always be connected to control unit **LES-RACK-M**. One Master unit allows up to 4 Slave units to be connected, each via its own dedicated communication line and within single fire compartment. Upon fire detection, all units are actuated simultaneously. Extinguishing system causes no damage whatsoever to data stored on storage media, extinguishing agent is electrically non-conductive and causes no corrosion. The system may also be used for extinguishing of electrical equipment under live nominal voltage up to 1000 V. Lifetime cycle of the system is 10 years from the year of production. The manufacturer's policy is to continuously upgrade its products' features and therefore company CONTEG, s.r.o. hereby reserves the right to change information and specifications contained in this manual without any prior notice.

I.2 Operating Conditions

The system is designed for installation in environments protected against weather impact, class 3K5 according to EN 60721-3-3 with temperature range from -5°C to 50°C, for environments classified as BNV according to ČSN EN 1127-1 and environments classified as AA4 according to ČSN 33 2000-3. For correct function of the equipment, its operating position and location in the enclosed protected space is critical. Operating position must always be horizontal, control panel must be easy to access and detection elements must extend beyond other devices located in the protected space. The system must be placed in the uppermost position in the cabinet. Working ability of the system is guaranteed within the temperature range from -5°C to 50°C with relative humidity 95% and in environment without sudden temperature changes, which could cause condensation and ice coating.

I.3 System Description

Individual parts of the system are placed and shockproof-anchored to duralumin body of the unit. Surface finish is red polyester powder paint (RAL3000), minimum layer of protective coating is 60 µm. Extinguishing unit is formed by cylindrical metal pressure cylinders (1) filled with extinguishing mixture (clean extinguishing agent HFC-236fa Hexafluoropropane according to the Certificate of Type issued by TÚPO – Technical Institute of Fire Protection, Authorized Body 221) and pressured by propelling gas (Nitrogen 5.0 – ČSN 65 4335). Cylinders are gas-tightly sealed by collecting fittings (2) with connection to filling device (3) and pressure gauge (4) allowing visual checking. Further, it also contains solenoid valve (5) and electronic pressure checking sensor (6). Detection elements (7) are located in the unit's rear part and are specially adjusted to provide maximum extension to free space ensuring maximum efficiency of their function. Actuation and control of **LES-RACK** is realized by integrated certified fire alarm control panel (FACP) unit LES-start-1 (8). Clear and uniform indication of the system's operating status is provided by LED controls on front panel reporting any current combination of function statuses. All light indicating LEDs may be manually checked to verify their correct operation. Pressure in the system is checked by analogue pressure checking switch, which is connected to the control unit. Unit's pressure may also be monitored by remotely connected supervising system. All terminal devices are equipped with relevant current protections. Extinguishing agent is expelled through special rising pipe via collecting pipe, solenoid valve and through special discharge nozzle (9) it is distributed and directed into the protected space. After use, the system may be re-filled, checked and re-used.

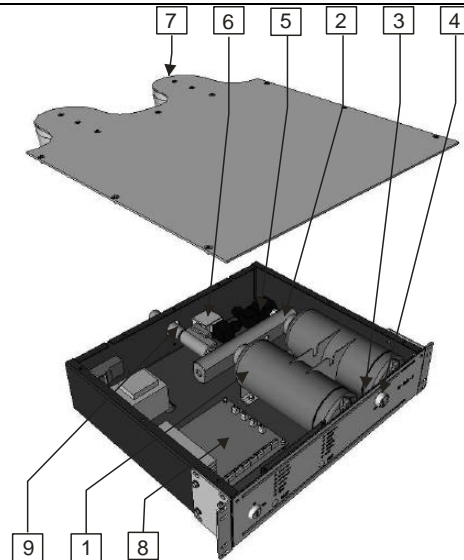

I.4 System Functionality Description

For detection of fire, each **LES-RACK** system is equipped with optical fire detectors, which – in order to eliminate false alarms – are interconnected in double-loop dependency and connected to the evaluation and control unit. Integrated control unit indicates system's current status, controls and evaluates actuation of the extinguishing unit. System **LES-RACK-M** allows communication with the fire alarm control panel (FACP) of the building and reports the following statuses: pre-alarm, alarm and extinguishing. In case one of the two detectors in pair detects fire, the unit triggers pre-alarm and acoustic and visual signalization activates. When smoke is detected by both detectors simultaneously, the system automatically enters the alarm status. This means automatic activation of output contact controlling the extinguishing unit, activation of acoustic and visual signalization of alarm status, and after pre-determined time delay the solenoid valves open and the protected space is flooded by the extinguishing agent from storage cylinders. System allows also for manual actuation by manual pushbutton **START** available as optional accessory.

I.5 General Safety Information



Activation of fire extinguishing system **LES-RACK** may expose the user to risks associated with natural characteristics of the extinguishing agent as such and possibly also with its decomposition products formed when the extinguishing agent gets in contact with fire or hot surfaces. User of the system is obliged to prevent any exposure of the operating personnel to the extinguishing agent as well as its decomposition products, in particular by providing trainings on regular basis. Activation of extinguishing system may be accompanied by sound with level sufficient to scare present person(s), but not loud enough to cause traumatic injury. Extinguishing agent discharged from the unit's nozzle at high speed may flow with sufficient force to move solid objects located directly in the extinguishing agent's path or its vicinity. Discharged agent may create flow in the protected space with force sufficient to move lightweight unfixed objects. Direct contact with the extinguishing agent discharged by the **LES-RACK** system may cause frostbite burns on skin. Liquid phase of the extinguishing agent, when mixed with air, evaporates rapidly thus limiting this risk only to imminent vicinity to discharge nozzle. In environments with high humidity, visibility might be temporarily slightly compromised due to water vapours condensation.

II. TECHNICAL SPECIFICATIONS

II.1 Extinguishing System Type Versions

II.1.1 **LES-RACK-M (MASTER)** – the device consists of main control unit, control and extinguishing unit with detection elements. The system works either as standalone or allows up to four additional SLAVE units to be connected in order to protect larger extinguishing compartments. Main control unit periodically checks the system status, possibly also including the SLAVE unit(s) status. Upon automatic activation by loops 1 and 2 by any of the units connected within the system (MASTER, SLAVE 1-4), or possibly when the manual pushbutton is activated, the compartment(s) protected by all units will be flooded simultaneously, provided that no part of the system reports door contact fault, i.e. open entrance to the extinguishing compartment implying possible presence of operating personnel and compromised extinguishing capability of the system due to increased volume of protected space.

II.1.2 **LES-RACK-S (SLAVE)** – the device consists of extinguishing unit, control unit with detection elements and is used as an additional unit to a MASTER unit to support extinguishing of larger compartments to be protected.

II.1.3 Schematic diagram of the **LES-RACK** system with key to attached devices and marked direction of communication. Bi-directional communication between the system and its accessories means that both the auxiliary device and connecting lines are monitored for fault-free operation.

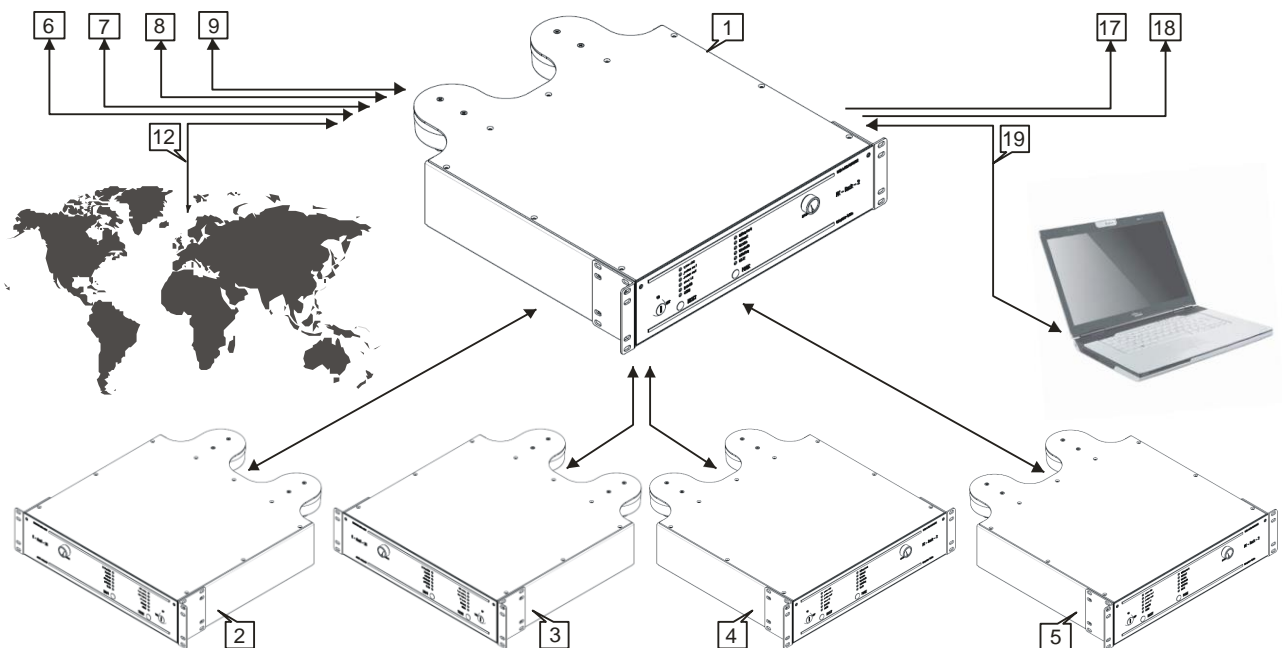

1	LES-RACK Master	2	LES-RACK Slave 1
3	LES-RACK Slave 2	4	LES-RACK Slave 3
5	LES-RACK Slave 4	6	Input for detection loop C
7	Input door contact	8	Input for external temperature sensor
9	Output for visual, acoustic signalization	12	Communication data line
17	Output for technology blocking	18	Output for HVAC blocking
19	Fault		

II.2 Main Technical Parameters

	LES-RACK-M	LES-RACK-S
Unit width	483 mm / 19"	483 mm / 19"
Unit height	105 mm / 2.5 U	105 mm / 2.5 U
Unit base depth	382 mm	382 mm
Total depth of detection extension, according to the depth of protected equipment	max. 750 mm	max. 750 mm
Weight of the system	15.5 kg ± 3 %	15.5 kg ± 3 %
Weight of extinguishing agent	2 kg	2 kg
Classification of environmental conditions according to EN 60721-3-3	3k5	3k5
Environment class	A	A
Operating temperature range	-5°C to 50°C	-5°C to 50°C
Relative humidity of air	95% non-condensing	95% non-condensing
Atmospheric pressure	70 to 106 kPa	70 to 106 kPa
Operating position	horizontal	horizontal
Operation type	permanent	permanent
Operating pressure at 20°C	10 bar	10 bar
Maximum operating pressure	16 bar	16 bar
Shielding according to ČSN EN 55022	class B device	class B device
Electrical input power	max. 40 VA	max. 40 VA
Protection class	IP 30	IP 30
Shielding class (non-interference)	RO2	RO2
Supply voltage of mains source	230 V ± 15 %	230 V ± 15 %
Supply frequency of mains source	50 Hz	50 Hz
Standby current	100 mA	100 mA
Current consumption during pre-alarm	150 mA	150 mA
Current consumption during alarm (powered from network)	300 mA	300 mA
Max. current consumed by outputs in standby	40 mA	40 mA
Max. current consumed by outputs during alarm	0.5 A	0.5 A
Max. output voltage on terminal X32 (batt. recharge)	13.7 V	13.7 V
Max. current from terminal X32 (batt. recharge)	200 mA	200 mA
Backup power source (150x94x65mm)	12 V/7.2 Ah	12 V/7.2 Ah
Acoustic signalization, fire alarm	82 dB	---
Acoustic signalization, fault, intermittent tone	76 dB	---

II.3 Design

Individual types of **LES-RACK** are manufactured by assembly of certified components, extinguishing units are filled with certified extinguishing agent and propelling inert gas. Welds and all joints of the extinguishing unit are gas-tight. Extinguishing agent is supplied to the fire by opening of solenoid valve installed on collecting pipe of the system terminated by special nozzle, which ensures perfect distribution of extinguishing agent in the protected space. Extinguishing unit is controlled by integrated fire alarm control panel (FACP) **LES-start-1**. The system is equipped with backup power supply source capable of maintaining the operation during mains power supply failure for up to 24 hours. Backup power supply source is recharged automatically. To ensure its maximum life-time cycle, temperature is checked in regular intervals. Based on temperature readings the charging current is adjusted. Failure

of both the mains and the backup power supply sources at the same time is indicated. Automatic detection of fire hazard is ensured by voltage-operated smoke detectors. To maintain high reliability of the system, automatic detection is blocked by the condition of so-called double-loop dependency (on separate lines 1 and 2) of alarm status and by delayed extinguishing action – during this delay, operating personnel may visually check the protected space and cancel the extinguishing action preparation process, if necessary. **LES-RACK-M** is equipped with line input for manual pushbutton (call point). All manual controllers are clearly marked to differentiate their purpose of use. By initializing such manual pushbutton the personnel starts immediate extinguishing action, maximum within 3 seconds, with no option to return the system to standby. The system is equipped with option to check whether doors are closed by TAMPER. In case the door is open, fault is reported and simultaneously the extinguishing agent discharge is blocked. TEST mode allows the personnel to periodically check functionality of all system's components.

	LES-RACK-M	LES-RACK-S
Extinguishing unit LES-stop (1-7) 2 kg	YES	YES
Integrated FACP LES-start-1	YES	NO
Integrated expander	NO	YES
Detection loop A+B with evaluation of mutual dependency for conventional voltage-operated smoke detectors	YES	YES
Analogue pressure check of extinguishing agent in cylinders	YES	YES
Auxiliary input – optical element EXT. FAULT	YES	NO
Internal acoustic signalization ALARM/FAULT	YES	NO
Relay outputs, voltage-free	YES	NO
Relay outputs, internal, voltage-operated	YES	YES
1x SOLENOID VALVE LES-stop	YES	YES
Optical signalization on front panel 1x Green OPER/TEST, 2x Red PRE-ALARM and ALARM, 10x Yellow FAULT = sum, A+B, pressure sum, accu, mains, valve, slave 1 to 4	YES	NO
Key protected switch for switching the operation status RESET/TEST-OPER	YES	NO
Pushbutton MUTE and RESET	YES	NO
On-board history log memory – communication connector on front panel of the unit	YES	NO
ETHERNET – communication module for service use included in supply of ETH connector on front panel of the unit	YES	NO
4x communication data line RS485 for interconnection of up to four LES-RACK-S units	YES	NO
Communication data line RS485 for connection to LES-RACK-M	NO	YES
Acoustic signalization	YES	NO
Backup power source 12 V/7.5 Ah	YES	YES
Mains power supply 230VAC on rear panel with fuse box and switch	YES	YES
Outputs of system reports and communication lines for SLAVE modules on rear panel	YES	NO

II.4 Material

Unit's chassis is made of duralumin, individual parts of the equipment are made of steel sheet, brass, pressed pieces of rubber and plastic. All materials are tested, they withstand prescribed operating conditions and used extinguishing agent, are stable and corrosion resistant during life-cycle of the system.

II.5 Surface Finish

After thorough degreasing, the surface of the device and storage cylinders is covered with red polyester powder paint (RAL3000). Minimum thickness of coat layer is 60 µm. Adherence conforms to grade 0-1 according to ČSN ISO 2409. Surface must not show faults, such as scratches, leaked paint, impurities, etc. All materials withstand prescribed operating conditions and used extinguishing agent.

II.6 Extinguishing Unit

Extinguishing unit consists of cylinder-shaped metal storage cylinders (1) filled with extinguishing mixture. Cylinders are gas-tightly sealed by collection fittings (2) providing connection to filling device (3) and pressure gauge (4) allowing visual checking. The unit also contains solenoid valve (5) and electronic pressure checking sensor (6). Extinguishing agent is expelled through special rising pipe via collecting pipe, solenoid valve and through discharge nozzle (9) it is distributed and directed into the protected space. Collecting fitting is made of brass equipped with

sealing rubber O-rings. Material is marked in compliance with drawing documentation, the same applies to embossed production number on the fitting body. Storage cylinders are marked by individual production numbers and all relevant data are recorded in the assembly sheet of the extinguishing unit collecting fitting together with records about checks performed during assembly.

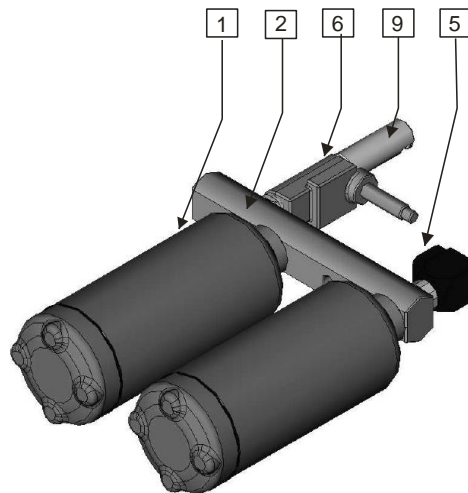

II.7 Control Unit

To ensure reliability, all system components are located on single board with printed circuits. The system includes a microcomputer controlled by microprocessor, control panel circuits and circuitry for monitoring the correct function of software. Connector XP2 allows connection of interface for serial transmission. Loop circuits contain circuitry for communication with microprocessor, which runs on enhanced bus. Also, they contain circuits, which control the loop status, output control and input read. Fire detection loops are located here along with circuits for relay outputs and relevant terminals. Power supply source circuit includes voltage stabilizer for power supply of the control unit, power supply circuit for control unit, circuit for recharging and control of the accumulator, diagnostic circuits and fuse to protect the backup power supply source. Automatic check of the system parts statuses is performed in regular intervals and measured values are recorded do history log memory. Control unit has connection for an adapter for serial communication via RS485. Communication between individual systems is made possible by connection using XP2 connector.

II.8 Communication, Remote Access and History Log

Each system **LES-RACK-M** has unique IP address, is able to send information about its status and can be remotely monitored by data network. As a standard, the device is equipped with Ethernet communication interface; upon special request and for extra charge this interface may be replaced with GPRS communication module. Communication in data network uses one serial channel, therefore only one of the above-mentioned communication means may operate at a time. Independent service data channel RS232 is used for service settings and readout of history log at the installation site, it is located at the front panel. All execution codes and data are stored in memory capable to operate without requiring any maintenance and working reliably for minimum 10 years. Memory contents, including stored data, is automatically checked in intervals not exceeding one hour. In case the control system finds out loss of memory contents, it reports system failure.

II.9 Detection Elements

II.9.1 Automatic detection – system component.

II.9.2 Photo-electric smoke detector, type OKB, is highly sensitive smoke detector with fast response designed for operation in ventilated environments and higher air flow rates. Status indication is

provided by LED. The detector connects to fire detection loop line by means of a socket. Robust black polycarbonate body guarantees long life-cycle. Detector's functionality is tested by testing aerosol.

II.9.3 Voltage-operated smoke detector, MHG 231.070, is intended for automatic signalization of fire as a detector of smoke. Detector is installed in places where smoke is expected to appear and collect. It works on principle of infrared radiation scattering on particles of smoke. Status indication is provided by LED. The detector connects to fire detection loop by means of MHY 734 socket. Detector's functionality is tested by testing aerosol.

II.9.4 Pushbutton for manual actuation – optional accessory for extra charge.

II.9.5 Voltage-operated manual pushbutton, MHA 108.132, is a fire protection device designed for manual actuation by a person who discovers the fire. How to use the pushbutton is indicated by instruction icon under glass cover of the pushbutton. After breaking the glass and pressing the pushbutton, a signal is sent from the manual pushbutton and activates fire signalization in the control unit. Manual pushbutton MHA 108 is used in interiors where permanent presence of persons is presumed or at places where application of automatic detectors would be inefficient (staircases, halls, etc.).

II.9.6 Manual pushbutton MHA 183 is a heavy duty addressable manual pushbutton intended for manual actuation by a person who discovers the fire. Manual pushbutton MHA 183 is designed for use at places not protected against weather impacts and at any other places, for which it is suitable due to its electrical protection class and weatherproof design. Manual pushbutton MHA 183 complies with requirements of standard EN 54-11. It is in particular suitable for explosion hazard environments (type of explosion protection is EEx nAC IIC T6) and also in places with no explosion hazard but where lightweight structure designs cannot be used, e.g. with increased demands for mechanical resistance.

II.9.7 Visual signalization lights – optional accessory for extra charge.

II.9.8 Visual signalization light, MHS 409, is used as a parallel optical signalization of fire alarm of one or multiple fire detectors connected in a single line (loop). It is intended for installation using distribution cables in conduits, mainly where no extra demands for increased mechanical resistance are applied (lightweight design).

II.9.9 Heavy duty visual signalization light MHS 408 is used as a parallel optical signalization of fire alarm of one or multiple fire detectors. This signalization light is intended especially for environments where due to increased mechanical requirements other types of visual signalization lights cannot be used, and also for signalization of function status of detectors located in explosion hazard environment in compliance with their TPTE, while the visual signalization light MHS 408 must, in such a case, be located outside such environment. Visual signalization light is connected to relevant fire detector by means of terminal socket MHY 713 or MHY 703.

II.9.10 Door contact switch – optional accessory for extra charge.

II.9.10.1 Universal countersabotage contact to protect the system. It is installed on all entrances to the protected space and is firmly fixed on the cabinet body. When disconnected, this contact switch indicates a fault and disables the extinguishing unit because opening the protected space compromises its tightness and safety of operating personnel.



II.10 Power Supply Source

Because the mains power supply may fail anytime, power supply for the system must be backed-up for certain time by replacement power source. The system is equipped with maintenance-free gas-tight lead accumulators with long service life. When the backup power supply source voltage drops below 10.5 V, it reports fault and the whole system shuts down. Fault signal from the terminal is activated. Accumulators' life-cycle directly depends on ambient temperature, its hold curves are stated in technical sheets by relevant manufacturer.

Only batteries of given type and parameters may be used in the system. In case the system has been out of service for more than 6 months, it is necessary to connect all devices to mains power supply for minimum 12 hours and allow the backup power supply sources to charge, thus preventing irreversible damage. Batteries must be neither opened, nor subject to any kind of tampering. Leaking electrolyte is dangerous to skin and eyes. Electrolyte may be poisonous.



II.11 Extinguishing Agent

The system **LES-RACK** uses clean extinguishing agent HFC-236fa (Hexafluoropropane C₃H₂F₆), Certificate of Type issued by Authorized Body 221 – Technický ústav požární ochrany MV (Technical Institute of Fire Protection of the Ministry of Interior) as of March 29, 2006. From the environmental protection point of view, this substance represents a clean extinguishing agent approved by relevant certification bodies, which complies with basic requirements for products as per § 3 of the Statutory Order No. 173/1997 Coll. Hexafluoropropane is a colourless gas with ether-like odour, with greater specific weight than air, electrically non-conductive, non-corrosive, with zero potential of impact to ozone layer. Extinguishing is performed by combination of physical and chemical effects, in particular by slowing down the chemical reaction in burning phase, it causes no harm to extinguished equipment. Minimum extinguishing concentration according to the ISO 14520-11 is 6.8%, while short-term presence in spaces with this extinguishing concentration is neither hazardous, nor harmful to human health and life. The lowest observed adverse effect level to human organisms is 15%. (Note: During fires, however, it is usually the concentration of toxic products of burning material that is harmful to life and health of humans.) This extinguishing agent allows the personnel present in protected space to finish the extinguishing action without direct impairment of health of present persons, simultaneously it causes no damage to protected equipment and data stored in such equipment. It must not contain any mechanical impurities and/or admixtures. Propelling gas is nitrogen 5.0 (ČSN 65 4335).

II.12 Marking

II.12.1 Extinguishing unit – assembly sheet of the unit kit contains identification data of used components; bottom lid of each cylinder contains embossed data of year of manufacture, testing pressure, producer's logo, reference number, cylinder volume, weight of empty cylinder, operational temperature range and CE marking; connecting piping has embossed serial number and material marking.

II.12.2 The system is equipped with special data production label (when someone tries to remove the label, it is destroyed), containing the following information:

- ✓ producer's name and address
- ✓ system type
- ✓ serial number
- ✓ minimum and maximum operating limits
- ✓ weight of empty system
- ✓ weight of filling
- ✓ type of extinguishing agent
- ✓ year of production

III. Requirements for Protected Equipment

III.1 Classification of Protected Space, Fire Safety

When designing location of **LES-RACK** system, the data given in the table below shall apply:

System type	Maximum volume of protected cabinet	
	Semi-opened (perforated)	Closed
LES-RACK-M	Max. 1.5 m ³	Max. 3 m ³
LES-RACK-S	Max. 1.5 m ³	Max. 3 m ³

Declared minimum extinguishing concentration is 6.8%. Minimum project design concentration is 8.8%. For perforated (semi-opened) racks the concentration is doubled due to presumed high losses of extinguishing agent. In rack cabinets, no presence of persons is anticipated and, simultaneously, great concentration of cabling is presumed, hence higher concentration of extinguishing agent is designed. Calculated values of the extinguishing agent concentration are appropriate.

III.2 Requirements for Protected Equipment

System **LES-RACK** performs extinguishing on the principle of flooding the protected space with clean gas and maintaining required extinguishing concentration inside the protected space. For proper function, working conditions defined for operation of **LES-RACK** system must be observed. Protected space must feature sufficient structural strength and tightness to hold the extinguishing charge and must be equipped with ventilation to prevent excessive over-pressurizing of the space. In order to prevent the extinguishing agent from leaking through apertures to adjacent endangered or working spaces, the apertures must be permanently sealed or equipped with automatic closing device. Forced ventilation in spaces where applicable must be automatically turned off by the **LES-RACK** system or closed in cases when its operation would negatively impact efficiency of the extinguishing system or could even result in fire spreading. Ventilation systems ensuring safety do not need to be turned off when the fire extinguishing system activates. In such case, however, it is necessary to calculate with extra volume of extinguishing agent to guarantee minimum design concentration during the required time of protection. For purposes of calculation of the extinguishing agent required volume, volumes of ventilated air as well as piping distribution of HVAC systems shall be considered as part of the total protected volume. All services inside the protected space (such as power connections, heating, etc.), which may compromise extinguishing system's efficiency, must be turned off by the **LES-RACK** system prior the extinguishing agent is discharged. To perform successful extinguishing action it is vital not only to achieve efficient concentration in determined time, but also to maintain this concentration for sufficient time to allow performing efficient measures. This is important for all kinds of fires because persisting sources of ignition, such as electric arc, heat source or "deep-seated fire" with center under the surface might cause re-ignition of fire once the extinguishing agent has been dissipated. Concentration hold time shall not be less than 10 minutes; perforated rack cabinets do not allow to guarantee to maintain efficient concentration of extinguishing agent and it is therefore necessary to ensure suitable and effective measures to prevent fire re-ignition.



Optical smoke detector works on the principle of infrared radiation dissipation on particles of smoke. At places where the system or such auxiliary detectors are used, all disturbing background effects must be minimized, such as dust, cigarette smoke, exhaust fumes, technical vapours, aerosols, etc.

IV. INSTALLATION

IV.1 General Provisions

LES-RACK system is designed for installation in enclosed spaces with no aggressive substances present. The system must not be subject to risk of mechanical damage, direct sunlight and working conditions outside allowed limits. Prior locating and installation the user is advised to consult local fire and safety regulations.

IV.2 Safety Provisions

From the protection against electrical accidents point of view, the standard ČSN EN 50110-1 "Operating and Works on Electrical Appliances" shall apply. The system may be installed only by persons informed at a minimum level according to § 4 of the Decree No. 50/1978 Coll., or No. 51/1978 Coll. Such persons must not in any case interfere with parts of circuits, with parts under cover connected with the mains where the danger of electrical accident is imminent. The system must not be commissioned and put into operation without initial revision.

IV.3 System Installation

The system is designed for universal installation in all types of 19" rack cabinets. The system may only be installed with its front panel facing the cabinet's door into special sliders supplied with the unit. The system must be installed in perfectly horizontal position. Sliders are screwed to the rack frame in the uppermost position of the cabinet. All fixing points must be duly tightened. Prior installation, sufficient space for mounting inside the cabinet must be provided. The system is attached to sliders by aligning the sliders with profiles on the unit. Once aligned, the unit must be moved to end position until the safety brackets on both sides click; these provide safe positioning in the rack cabinet. When removing the unit proceed vice versa: push the unit as far as it goes and disengage the brackets' arms.

In order to improve response time of smoke detectors, the unit is equipped with adjustable extension holder allowing to set overall depth of the device, thus allowing to position the detectors in suitable position in the protected space. Adjustments require loosening the locking screws by Allen wrench No. 3 on both sides of the unit and extending the whole holder with detectors to suitable depth. Take proper care while extending the holder because cables to detectors are led through inside of the holder and careless handling may result in damage inside the unit. When adjustments are finished, tighten the locking screws on both sides properly.

IV.4 Commissioning

Commissioning of **LES-RACK-M** and **LES-RACK-S** – the system is put into fully functional operation automatically by connecting the mains power supply 250V/10A, while the key switch 22-OPERATION/TEST is in TEST position and the main switch is in position 1 (ON). The system will perform necessary tests and checks and will enter the TEST mode operation.

IV.5 System Mains Power Supply

Power supply cord of the device is designed as an extension cord 250V/1A to be plugged to a EURO-type socket in the device. The socket is equipped with main ON/OFF switch and mains fuse box 0,315 A. Before putting the system into operation the main switch must be switched to position 1 (ON).

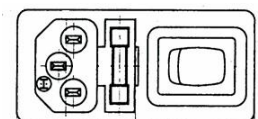

IV.6 Switching Off the System

LES-RACK-M system is switched off by putting the key switch 22-OPERATION/TEST to position TEST, unplugging the power supply cable or turning the main switch to position 0 (OFF). The system switches to operation using the backup power supply source and by pressing the pushbuttons 23-RESET and 24-MUTE simultaneously for 20 sec the system will switch off completely.

LES-RACK-S system is switched only after switching off the Master system by unplugging the power supply cable or turning the main switch to position 0 (OFF). The system switches to operation using the backup power supply source. If in this mode no communication with Master unit is established (Master must be switched off), the unit will switch off automatically after 5 minutes.



Important notice: In case the system has been out of service for more than 6 months, it is necessary to connect all devices to mains power supply for minimum 12 hours and allow the backup power supply sources to charge, thus preventing irreversible damage.

IV.7 Installation of Cables

All electrical installations and works must be performed in compliance with codes of practice and legislation applicable in given country. If possible, SELV-type cables should be led separately from high-voltage LV-type cables. It is important to ensure proper cable routes, which would minimize mutual interference. In particular, a single conduit should not contain both power cables with signal data cables of the system. To minimize the effects of EMC interference all data wiring circuits should be wired with a twisted pair of conductors with a cross sectional area suitable for the loading conditions. In areas where cabling may come into contact with high frequency interference, such as portable radio transceivers etc., the output wiring cable should be of a twisted pair construction within an overall screen. The screen should be duly terminated.

IV.8 Recommended type of Cables

To connect the parts of the system LES-RACK is required to use cable type JXFE-V 2x2x0.8. Cable with increased resistance against flame spread and increased functional ability in fire at least 180 min. The cable is not designed for permanent bending, the attachment must be always fixed. Permissible bending radius when leadership is 7.5 x cable diameter, minimum temperature during installation must be + 5 °C.

IV.9 Installation of External Components

- IV.9.1 Manual pushbutton – must always be installed outside the protected space or in vicinity of main entrance. Two actions are always necessary to activate the pushbutton: to break the protection glass and to push the button. When pressed, the manual pushbutton activates the extinguishing system without any time delay. The pushbutton must be installed firmly, mounted into the solid structural or building part.
- IV.9.2 Door contact – must be installed at the entrances to the protected space in compliance with the installation manual supplied with the door contact. In case the protected space has more entrances, the door contacts must be connected in series, maximum five door contact switches in total.
- IV.9.3 Visual and acoustic signalization – this signalization must be differentiated from all other signalization devices used in the object. Must be located outside the protected space. It will be activated in the beginning of time delay countdown after the system detects fire. The signalization devices must be installed firmly, mounted into the solid structural or building part.
- IV.9.4 External temperature sensor – shall be installed in the space where the temperature is to be monitored. Temperature may be checked via serial interface. No function of the system is related with the temperature sensor, it serves solely for temperature readouts.

IV.10 Connection of External Input and Output Devices

Terminal board in the rear part of the unit provides inputs and outputs to connect individual components. Connections are described by the **LES-RACK** system wiring diagram with key to devices, which may be connected, listed in the table below. Directions of communication are given in the diagram in chapter “System Type Versions”; bi-directional communication between the system and its accessories means that both the auxiliary device and connecting lines are monitored for fault-free operation and fault is indicated on the unit’s front panel. Cables must be led according to instructions given in chapter “Installation of Cables”. All cables must be duly marked, fixed and tightened in the terminal board (min. 4.3 Nm).

Pos.	Terminals	Line Parameters	Line Function	Wire Dimensioning
2-5	A - B	RS485 line	Communication Master – Slave	0.8 mm ² /max. 10 m
6	1 - 2	Loop C input, monitored for faults	Manual actuation pushbutton	0.8 mm ² /max. 10 m
7	3 - 4	NC input	Door contact	0.8 mm ² /max. 10 m
8	5 - 6	Analogue value input	External temperature sensor	0.8 mm ² /max. 10 m
9	7 - 8	Output monitored for faults	Visual and acoustic signalization	0.8 mm ² /max. 10 m
12	front panel	RS232	Service interface, local	
17	9 – 10 - 11	Output SPDT – switching contacts	Technology blocking	0.8 mm ² /max. 10 m
18	12 – 13 - 14	Output NTSC – switching contacts	HVAC blocking	0.8 mm ² /max. 10 m
19	rear panel	10/100 Mbps	Service interface Ethernet	

LES-RACK-M connection

+	GND	-					+	-	C	NC	NO	C	NC	NO
1		2	3	4	5	6	7	8	9	10	11	12	13	14

LES-RACK-S connection

				+	-
3	4	5	6	7	8

IV.10.1 Manual actuation pushbutton – connect input to terminals 1 (positive pole) and 2 (negative pole). Manual pushbutton type MHA 108.132.



IV.10.2 Door contact – connect line with parameters given in the table between terminals 3 and 4; when door is closed, the contact switch must be closed. If this switch is open (door open), extinguishing function is blocked. This status is indicated on the unit's front panel. If the protected space has more entrances, door contacts must be connected in series, maximum five door contact switches in total.

IV.10.3 External temperature sensor – terminals 5 and 6, resistance temperature sensor type KTY 10-6.

IV.10.4 Output for visual and acoustic signalization – voltage-operated relay output connects to terminals 7 (positive pole) and 8 (negative pole) for external acoustic or visual signalization. In monitoring status the polarity is reverse and output voltage is 10.3V. During PRE-ALARM, ALARM and FAULT, the polarity is inverted. Load: 24V/500mA resistive load.

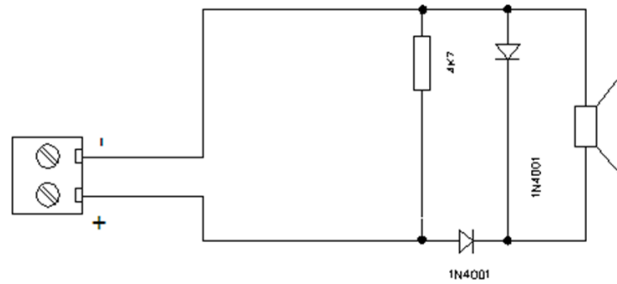

- IV.10.5 Technology blocking – switching contacts 9, 10, 11 to control external device. Switching contact values: 1A/24V VDC. Should an inductive load be controlled, the relay contacts must be equipped with relevant arc control devices.
- IV.10.6 HVAC blocking – switching contacts 12, 13, 14 to control external device. Switching contact values: 1A/24V VDC. Should an inductive load be controlled, the relay contacts must be equipped with relevant arc control devices.
- IV.10.7 Communication line Master–Slave – type RS485 line is used solely for communication between Master and Slave units. Communication fault is indicated on the unit’s front panel and differentiated by individual system where the fault occurred (Slave 1-4).

LES-RACK-M connection

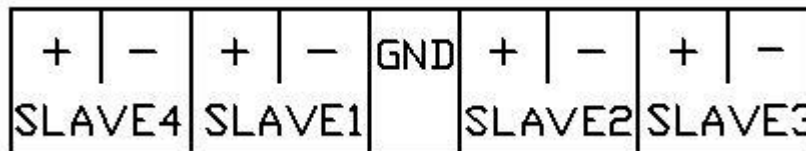

LES-RACK-S connection



V. CHECKS AND COMMISSIONING

V.1 Line Testing

- V.1.1 To ensure safe and reliable operation of the system, it is advisable to perform lines insulation test. Faults caused by cabling errors can be remedied at a later time only by troublesome actions and higher costs. Tests may also be carried out section by section. Testing results shall be recorded.
- V.1.2 Insulation test. Before measuring the insulation (leaking) resistance, check that all electrical devices are unplugged from the line. Insulation resistance wire-to-wire and wire-to-ground should be measured by special instrument calibrated for measuring the insulation resistance. Measured insulation resistance of properly installed cabling should be higher than 10 MΩ. If the insulation resistance is lower, such cable must be checked for damages.

V.2 Check of the Devices’ Fixed Position



This check involves fixing of all parts of devices, parts of protected equipment, technology located inside the protected space, cabling and joints, etc. Extinguishing agent discharged to the protected space may create flow sufficient to move lightweight unfixed objects or possibly loosen improperly fixed components.

V.3 System Functionality Check

After installation and commissioning, comprehensive tests of functionality shall be performed. The following functions are tested:

- V.3.1 test of signalization components
- V.3.2 signalization of fire on loops 1, 2, C (manual pushbutton)
- V.3.3 signalization of pressure drop on loop PRESSURE
- V.3.4 signalization of fault from loops 1, 2, C, PRESSURE (short circuit, cut-off)
- V.3.5 signalization of fault from acoustic and visual signalization line (short circuit, cut-off)
- V.3.6 signalization of fault from solenoid valve line (short circuit, cut-off)
- V.3.7 signalization of mains power supply fault (electrical mains)
- V.3.8 signalization of backup power supply source fault (accumulator)
- V.3.9 signalization of fuses fault
- V.3.10 signalization of fault received from external device
- V.3.11 check of outputs ALARM, PRE-ALARM 1 or 2
- V.3.12 check of output FAULT
- V.3.13 check of output TEST
- V.3.14 check of output to control solenoid valve in extinguishing unit
- V.3.15 check of output for external acoustic or visual signalization

V.4 Check of Detection Elements

Individual detectors (call points) connected to loops may only be checked in TEST mode. Detectors' functionality is checked by prescribed procedure using testing aerosol suitable for given type of installed detector. If check by aerosol cannot be used for certain detectors, they shall be removed from their sockets (terminal board) and their parameters shall be measured. Detectors that fail to pass the test, shall be replaced with new ones of the same type.

VI. OPERATION

VI.1 General Requirements



LES-RACK system is designed and produced for fully automatic operation. Therefore, all functions of the system are carried out automatically and user cannot make any configuration alterations. Front panel offers indicating LEDs providing information about operational statuses and current processes of the system. Unit's cover may only be opened by person authorized by the service organization. Electric shock hazard is imminent with cover open. System user is obliged to appoint and arrange training for persons responsible for the system operation, operating personnel and persons responsible for system maintenance who will in detail make themselves familiar with this instruction manual. When training persons responsible for maintenance, due care must be focused on proper procedures to ensure that during maintenance they will not activate the extinguishing system. To ensure safe and faultless operation, never leave key inside the key switch 22-OPERATION/TEST. It is advisable to restrict or control access of unauthorized persons to place where the extinguishing system is located.



VI.2 LES-RACK-M – Overview of Status LEDs and Control Elements

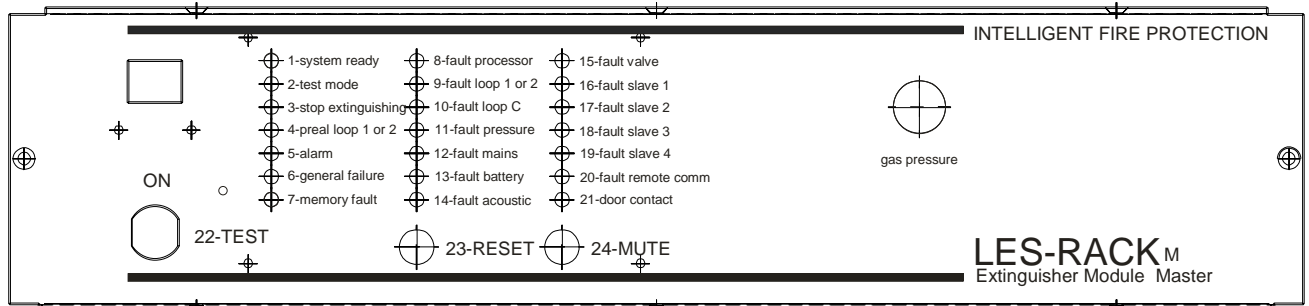

1	Operation	Green is lit	T
2	Test	Green blinks	PP
3	Emergency switch-off	Yellow is lit	P
4	Pre-alarm 1 or 2	Red is lit	S
5	Alarm	Red is lit	S
5	Alarm	Red blinks fast	S
5	Alarm	Red blinks slowly	S
6	Fault general	Yellow is lit	P
7	Fault memory	Yellow is lit	P
8	Fault processor	Yellow is lit	T
9	Fault 1 or 2	Yellow is lit	P
10	Fault C	Yellow is lit	P
11	Fault pressure	Yellow is lit	P
11	Fault pressure	Yellow blinks	P
12	Fault power supply	Yellow is lit	P
13	Fault ACCU	Yellow is lit	P
13	Fault ACCU	Yellow blinks	T
14	Fault signalization	Yellow is lit	P
15	Fault valve	Yellow is lit	P
16	Fault Slave 1	Yellow is lit	P
17	Fault Slave 2	Yellow is lit	P
18	Fault Slave 3	Yellow is lit	P
19	Fault Slave 4	Yellow is lit	P
20	Fault communication	Yellow is lit	P
21	Fault tamper	Yellow is lit	P
22	OPERATION/TEST	System status switch	
23	RESET	Pushbutton	
24	MUTE	Pushbutton	T

Acoustic signalization: T-silence, S-continuous sound, P-intermittent tone (interval 1 s),
PP-slow intermittent tone (interval 10 s)

VI.3 LES-RACK-S – Overview of Status LEDs and Control Elements

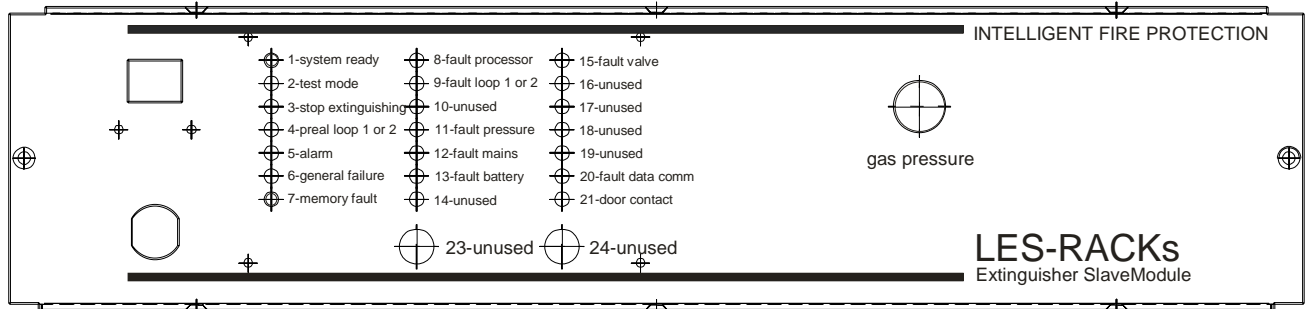

1	Operation	Green is lit	T
2	Test	Green blinks	T
3	Emergency switch off	Yellow is lit	T
4	Pre-alarm 1 or 2	Red is lit	T
5	Alarm	Red is lit	T
5	Alarm	Red blinks fast	T
5	Alarm	Red blinks slowly	T
6	Fault summary	Yellow is lit	T
7	Fault memory	Yellow is lit	T
8	Fault processor	Yellow is lit	T
9	Fault 1 or 2	Yellow is lit	T
10	Not used		
11	Fault pressure	Yellow is lit	T
11	Fault pressure	Yellow blinks	T
12	Fault power supply	Yellow is lit	T
13	Fault ACCU	Yellow is lit	T
13	Fault ACCU	Yellow blinks	T
14	Not used		
15	Fault valve	Yellow is lit	T
16	Not used		
17	Not used		
18	Not used		
19	Not used		
20	Fault communication	Yellow is lit	T
21	Fault tamper	Yellow is lit	T
22	Not used		
23	Not used		
24	Not used		

Acoustic signalization: T-silence, S-continuous sound, P-intermittent tone (interval 1 s),
PP-slow intermittent tone (interval 10 s)

VI.4 Description of LES-RACK Control Elements

- 1) OPERATION – is lit when the system is fully operational.
- 2) TEST – blinks in test mode. Acoustic signalization inside the unit indicates this mode by short tone sounding once in 5 seconds. In test mode, all functions of the system are active, only discharge of extinguishing agent is blocked.
- 3) EMERGENCY SWITCH-OFF – this LED is lit when extinguishing process is blocked, e.g. by opening the door contact switch.
- 4) PRE-ALARM 1 or 2 – these LEDs are lit when loop 1 (detector 1) or loop 2 (detector 2) report alarm. Time delay Tz counts down. Loop of external acoustic signalization and loops blocking technology and HVAC are active.
- 5) ALARM – extinguishing agent is being discharged.
 - a. ALARM – LED blinks fast when time delay Tz counts down and loops 1+2 are active. This status may be cancelled by pressing pushbutton 23-RESET, the system will return to monitoring status and will respond to new alarm(s). Time delay Tz is a time, during which alarm can still be cancelled. Factory default setting is 30 s.
 - b. ALARM – LED is lit when alarm signal comes from loop C (manual pushbutton loop) or in case of alarm from loops 1+2 after the time delay Tz has expired. If the ALARM LED is lit, the output opening the solenoid valve is active and extinguishing agent is being discharged. This status cannot be cancelled from the front panel.
 - c. ALARM – LED blinks slowly after completed ALARM status, i.e. discharge. Alarm status can be reset after the solenoid valve was opened by turning the key switch to TEST position and pressing the RESET pushbutton. All LEDs on the front panel will light up for 1 second and simultaneously the internal acoustic signalization inside the unit will sound.
- 6) FAULT – summary fault when LED of specific fault lights up. All individual faults are indicated by the acoustic signalization inside the unit using intervals (sound patterns) listed in the table above.
- 7) FAULT MEMORY – this LED is lit when the backup memory checksum is not correct.
- 8) FAULT PROCESSOR – this LED is lit when the processor and hence the complete system fail critically. This is the only LED on the front panel not controlled by the processor.
- 9) FAULT 1 or 2 – these LED are lit when loops 1 or 2 (smoke detectors 1 or 2) experience short circuit or become disconnected.
- 10) FAULT C – this LED is lit when loop C (manual pushbutton loop) experiences short circuit or becomes disconnected.
- 11) FAULT PRESSURE – this LED is lit when loop to storage cylinders experiences short circuit or becomes disconnected. When pressure in storage cylinders drops below allowed limit, this LED will blink.
- 12) FAULT POWER SUPPLY – this LED is lit when the mains (230V) power supply fails.
- 13) FAULT ACCUMULATOR – this LED is lit when the backup power supply source is disconnected or fails. The LED blinks when the accumulator is being charged.
- 14) FAULT ACOUSTIC SIGNALIZATION – this LED is lit when line to external acoustic signalization experiences short circuit or becomes disconnected.
- 15) FAULT VALVE – this LED is lit when loop to solenoid valve on storage cylinders experiences short circuit or becomes disconnected, simultaneously the coil impedance is being measured. Fault is reported when the coil impedance increases by more than 30%.
- 16) FAULT SLAVE 1 – this LED is lit when a SLAVE module is present in the system and indicates its faulty condition. Detailed information about specific fault on the SLAVE module is indicated on its own front panel. Fault statuses are also recorded to history log memory. This LED indicates also fault on communication line between Master and Slave.
- 17) FAULT SLAVE 2 – this LED is lit when a SLAVE module is present in the system and indicates its faulty condition. Detailed information about specific fault on the SLAVE module is indicated on its own front panel. Fault

statuses are also recorded to history log memory. This LED indicates also fault on communication line between Master and Slave.

- 18) **FAULT SLAVE 3** – this LED is lit when a SLAVE module is present in the system and indicates its faulty condition. Detailed information about specific fault on the SLAVE module is indicated on its own front panel. Fault statuses are also recorded to history log memory. This LED indicates also fault on communication line between Master and Slave.
- 19) **FAULT SLAVE 4** – this LED is lit when a SLAVE module is present in the system and indicates its faulty condition. Detailed information about specific fault on the SLAVE module is indicated on its own front panel. Fault statuses are also recorded to history log memory. This LED indicates also fault on communication line between Master and Slave.
- 20) **FAULT COMMUNICATION**
 - a. **REMOTE COMMUNICATION FAULT (Master)** – this LED lights up to indicate faulty status of communication with remote supervising center (Ethernet, GPRS), or possibly with service software.
 - b. **DATA COMMUNICATION FAULT (Slave)** – this LED lights up to indicate faulty status of serial data line between Master and Slave.



- 21) **DOOR CONTACT** – this LED lights up when the door contact switch on monitored door opens. When this contact is open (door open), extinguishing function is blocked.
- 22) **Key switch OPERATION/TEST** – in TEST position the system performs all operations and functions as in the OPERATION status – only the function of powering the solenoid valve, i.e. allowing the extinguishing agent to discharge, is disabled. Status OPERATION is fully monitoring condition. Upon switching to this status, the system automatically tests all loops, testing takes roughly 30 seconds. Alarm status can be reset after the solenoid valve was opened by turning the key switch to TEST position and pressing the RESET pushbutton. All LEDs on the front panel will light up for 1 second and simultaneously the internal acoustic signalization inside the unit will sound.
- 23) **RESET pushbutton** – resets alarms reported by loops 1 and 2. In case the cause of alarm at loops 1 and 2 persists, alarm status will be automatically re-established once the pushbutton is released. If ALARM status is activated by both loops or by manual pushbutton, holding the RESET pushbutton interrupts discharging the extinguishing agent. Discharging will continue immediately after the pushbutton is released.
- 24) **MUTE pushbutton** – cancels the system's both internal and external visual and acoustic signalization.

VII. MAINTENANCE

VII.1 General Provisions



System user must observe scheduled checks, prepare a service plan and keep records on checks and repairs. Permanent ability of the **LES-RACK** system to maintain effective efficiency fully depends on adequate service procedures with regular testing. Prescribed checks of the **LES-RACK** system may only be performed by persons with required qualification. Such persons must not in any case interfere with parts of circuits under cover connected with the mains because here the danger of electrical accident is imminent. Service works may only be carried out by duly and positively trained employees of service organization or manufacturer. Prior starting any check of the **LES-RACK** system, person responsible for the system operation must be informed beforehand. Prior starting any check and putting the system into operation it is necessary to prevent undesired activation of related equipment, if applicable, such as power supply shut down, closing of fire dampers, air-conditioning units. The system must also undergo checking always after each activation or when operational limits have been exceeded.

VII.2 Checks Performed by User

Consistent observation of scheduled checks and maintenance will allow finding possible faults of the **LES-RACK** system in early stage. This allows to remedy such faults before it will be necessary for the system to activate

automatically, thus ensuring perfect functionality in case of fire. Each completed check must prove compliance with general requirements and technical parameters listed in this manual.

VII.2.1 Weekly check

Visually check whether the risks and tightness of the protected space have not been altered, which might compromise the system's extinguishing efficiency. Visually check whether all operational devices and system components are on due places and show no damage. Check pressure gauges and devices monitoring pressure drop in storage cylinders whether measured values comply with required technical parameters.

VII.2.2 Monthly check

Check whether all personnel who might possibly work with the system are duly trained and have proper qualification for such activities. In particular, check whether newly employed persons have received appropriate training to use and operate the system.

VII.3 Checks of the Protected Space

Minimum once a month check thoroughly whether no leaks in the enclosure of the protected space occurred and/or that no other changes took place, which might affect the hold time and extinguishing efficiency. If checks reveal that protected space was subject to changes of volume or type of hazard, or both, the extinguishing system must be re-designed to provide original level of protection as a standard. When making any changes in protected space it is advised to check type of hazard and consider changes in volume. This is recommended to be checked regularly to ensure that required extinguishing agent concentration will be reached and maintained.

VII.4 Checks Performed by Service Organization



Service works may only be carried out by duly trained employees of service organization qualified in electro technical sphere according to applicable regulations.



VII.4.1 Quarterly check

All electrical detection and alarm systems are tested according to recommendations in applicable national standards.

VII.4.2 Semi-annual check

The following checks and inspections are performed.

All control valves are checked for proper manual operation and subsequently whether they work correctly for automatic operation. Check the unit's surface for signs of mechanical damage or unauthorized tampering.

VII.4.3 Annual check

1. Visually check the following
 - a. check the unit's location
 - b. check serial number
 - c. check fixture in place
 - d. check accessibility
 - e. clean the system from dirt
2. Check system pressure gauge
 - a. visually check pressure on the pressure gauge, required value is listed in table with main technical parameters
 - b. check pressure gauge seal
3. Check pressure switch
 - a. check transmission of signal to control unit
 - b. check functionality of pressure switch using calibrated instrument
 - c. check pressure switch seal

4. Check communication with the main fire alarm control panel system (FACP)
 - a. check transmission of relevant signals
5. Check and test automatic detection and manual activation of extinguishing action
 - a. check reporting fault of monitoring line by removing a detector from its socket
 - b. check function of smoke detectors
 - c. check function of external fire detectors, if applicable
 - d. check manual pushbutton function using testing key
 - e. check impedance of monitoring line by measurements
6. Check and test detectors, check pressure in extinguishing agent storage cylinders
 - a. visually check pressure switches
 - b. check function of pressure switches, simulate pressure drop condition (on socket of the switch)
 - c. check impedance of monitoring line by measurements
7. Check and test output devices
 - a. visually check signalization and output components
 - b. check function of visual and acoustic signalization
 - c. simulate extinguishing condition
 - d. check hold force of solenoid valves coil
 - e. check impedance of monitoring line of solenoids

VII.5 Checks and Service via Serial Interfaces

Connection via RS232 line to portable PC (notebook) and testing for one hour by service software, including evaluation. Connection via crossed cable (lap link). Service notebook may be connected only when the system is powered by accumulator. For safety reasons and protection of the system the system must not in any case powered by mains.

Connection via Ethernet line by LAN cable (Ethernet) and using service software.

Each performed check, repair, or possibly any other action on the system, must be documented, clearly recording performed actions, unit's condition before and after the action, identification data about persons who performed the actions and protocol on functionality after the checks are accomplished.

VII.6 List of Accessories and Spare Parts

VII.6.1 List of accessories and spare parts supplied to user

	Ordering Number	Description	Designation / type
1	LES-52LEFK14071	Backup power supply source	GP 1272
2	LES-14LE00100253	Spare lock OPERATION/TEST	
3	LES-14LE00100255	Smoke detector photoelectric	OKB
4	LES-52LEFK14071	Smoke detector optical	MHG 231.070
5	LES-52LEFK1411	Socket for smoke detector	MHY 734.029
6	LES-14LE00100254	Door contact switch, tamper	
7	LES-52LEFK1408	Manual pushbutton	MHA 108.132
8	LES-52LEFK14081	Manual pushbutton, heavy-duty	MHA 183
9	LES-52LEFK1424	Signalization light	
10	LES-14LE00100111	Checking pressure gauge	
11	LES-14LE00100251	Power supply cord EURO socket	
12	LES-14LE00100252	Power supply cord UPS socket	

VII.6.2 List of accessories and spare parts supplied to service organization

	Ordering Number	Description	Designation / type
1	LES-14LE00100261	Fire extinguishing unit – complete	
2	LES-14LE00100265	Control unit – complete	
3	LES-14LE00100296	Testing aerosol	
4	LES-14LE00100298	Boom for checking smoke detectors	

VIII. ENVIRONMENTAL ASPECTS

VIII.1 System’s Life-Cycle

Systems older than 10 years, systems with irreparable fault or systems where the serial number and year of production cannot be safely identified must be put out of service in compliance with the Waste Disposal Act or directly at the manufacturer’s premises. Rules for disposal with electric and electronic waste are set forth by Directive 2002/96/EC of the European Parliament and of the Council.

VIII.2 Environmental Impact

Dispose the system by handing it over to a collection point for recycling the electric and electronic waste. In the European Union member countries it is possible to use various collection systems for disposing the electric and electronic products. By ensuring proper disposal you will help prevent occurrence of potential hazards to environment and human health possibly resulting from improper handling with wastes. Where their dimensions allow, all parts carry printed symbols of materials used for production as well as for recycling. The system is equipped with maintenance-free, gas-tight lead accumulators with long service life. End user is responsible for returning the used batteries back. Disposal of batteries in household waste is forbidden. Batteries containing hazardous substances are marked by symbol indicating the ban to liquidate them as a household waste. Important heavy metals are marked as follows: Cd=cadmium, Hg=mercury, Pb=lead. With respect to protection of the environment, the batteries (accumulators) must be disposed of by means of dedicated collection networks, by means of authorized service organization or directly at the manufacturer’s premises. Do not throw batteries in fire, they may explode. Batteries must be neither opened, nor subject to any kind of tampering. Leaking electrolyte is dangerous to skin and eyes, it may be poisonous. The system’s packaging is made of paper carton (PAP), both the packaging and metal parts may be recycled.



VIII.3 Material Safety Data Sheet – Extinguishing Agent HFC-236fa

=====

CHEMICAL PRODUCT / COMPANY IDENTIFICATION

=====

Material Identification

CAS No. 690-39-1

Formula CF3-CH2-CF3

CAS name 1,1,1,3,3,3-hexafluoropropane

Trade Names

HFC-236fa

HEXAFLUOROPROPANE

Company Identification

Company name: ZHEJIANG CHEH-TECH GROUP CO. LTD.

Street: No. 926 XI XI ROAD

City: HANGZHOU

State: ZHEJIANG

Province: CN

ZIP Code: 310023

=====

COMPOSITION/INFORMATION ON INGREDIENTS

=====
Ingredients

Material CAS Number CAS 690-39-1

1,1,1,3,3,3-HEXAFLUOROPROPANE (HFC-236fa) 99-100
=====

HAZARDS IDENTIFICATION

=====
Potential Health Effects

Based on animal data, exposure to HFC-236fa by inhalation may cause suffocation, if air is displaced by vapours, and irregular heart beat with a strange sensation in the chest, "heart thumping", apprehension, lightheadedness, feeling of fainting, dizziness, weakness, sometimes progressing to loss of consciousness and death.

HFC-236fa may cause frostbites if liquid or escaping vapour contacts the skin.

HFC-236fe may cause "frostbite-like" effects if the liquid or escaping vapours contact the eyes.

Ingestion is not considered a probable route of exposure for HFC-236fa.

Carcinogenicity Information

None of the components present in this material at concentrations equal to or greater than 0.1% are listed by IARC, NTP, OSHA or ACGIH as a carcinogen.
=====

FIRST AID MEASURES

=====
First Aid

INHALATION

If inhaled, immediately take the affected person to fresh air. Keep the person calm. If not breathing, give artificial respiration. If breathing is difficult, apply oxygen. Call a physician.

SKIN CONTACT

Flush affected area with lukewarm water. Do not use hot water. If frostbite has occurred, call a physician.

EYE CONTACT

In case of contact, immediately flush eyes with plenty of water for at least 15 minutes. Call a physician.

INGESTION

Ingestion is not considered a potential route of exposure.

Notes to Physicians

THIS MATERIAL MAY MAKE THE HEART MORE SUSCEPTIBLE TO ARRHYTHMIAS.

Catecholamines such as adrenaline, and other compounds having similar effects, should be reserved for emergencies and then used only with special caution.
=====

FIREFIGHTING MEASURES

=====
Flammable Properties

Will not burn. Not a fire or explosion hazard. HFC-236fa is used as a fire extinguishant.

Hazardous gas/vapour produced in fire is hydrogen fluoride.

Extinguishing Media

Use media appropriate for surrounding material.

Fire Fighting Instructions

(For example: when HFC-236fa is exposed to fire from surrounding material) - Wear self-contained breathing apparatus. Wear full protective equipment. Cool tank/container with water spray.
=====

ACCIDENTAL RELEASE MEASURES

=====
Safeguards (Personnel)

NOTE: Review FIRE FIGHTING MEASURES and HANDLING (PERSONNEL) sections before proceeding with clean-up. Use appropriate PERSONAL PROTECTIVE EQUIPMENT during clean-up.

Keep upwind of leak - evacuate until gas has dispersed

Accidental Release Measures

Ventilate area before re-entering.
=====

HANDLING AND STORAGE

=====

Handling (Personnel)

Do not breathe gas. Do not allow to get in eyes, on skin, or on clothing.
Wash thoroughly after handling.

Handling (Physical Aspects)

Keep away from sparks, flames and hot (glowing) surfaces.

Storage

Keep container in a clean, dry place. Keep container tightly closed. Do not heat above 52 degrees C (126 degrees F).

=====

EXPOSURE CONTROLS/PERSONAL PROTECTION

=====

Engineering Controls

Use only with adequate ventilation. Keep container tightly closed. Vapours of the compound are heavier than air, posing a hazard of asphyxia if they are trapped in enclosed or low places.

Personal Protective Equipment

EYE/FACE PROTECTION

Wear safety glasses or coverall chemical splash goggles.

RESPIRATORS

Wear NIOSH approved respiratory protection, as appropriate.

PROTECTIVE CLOTHING

Wear impervious clothing, such as gloves, apron, boots, or whole bodysuit as appropriate.

Exposure Guidelines, Exposure Limits HFC-236fa

PEL (OSHA): None Established

TLV (ACGIH): None Established

AEL* (DuPont): 1000 ppm, 8 and 12 hours TWA

WEEL (AIHA): 1000 ppm, 8 hours TWA

* AEL is DuPont's Acceptable Exposure Limit. Where governmentally imposed occupational exposure limits which are lower than the AEL are in effect, such limits shall take precedence.

=====

PHYSICAL AND CHEMICAL PROPERTIES

=====

Physical Data

Boiling point: - 1.4 °C (29.5 °F) at 760 mm Hg

Vapour pressure: 272.4 kPa at 25 °C (77 °F)

Melting point: -98 °C (-144 °F)

Freezing point: -93.6 °C (-136.5 °F)

Form: Liquefied gas

Colour: Colourless

Density: 1.370 g/cm³

=====

STABILITY AND REACTIVITY

=====

Chemical Stability

Stable

Incompatibility with Other Materials

Incompatible with strong bases, metallic sodium, potassium, lithium.

Decomposition

Decomposes in open flames and hot (glowing) surfaces.

Hazardous gas/vapour produced in fire is hydrogen fluoride.

Polymerization

Polymerization will not occur.

=====

TOXICOLOGICAL INFORMATION

Animal Data

HFC-236fa:

Inhalation 4 hours LC50: > 457,000 ppm in rats

CONTEG, spol. s r.o.

Na Vítězné pláni 1719/4, 140 00 Prague 4, Czech Republic



Single exposure by inhalation caused narcosis and cardiac sensitization, a potentially fatal disturbance of heart rhythm associated with a heightened sensitivity to the action of epinephrine. Repeated exposures caused a reduced startling response in rats. No other significant toxicological effects were observed.

No-Observed-Adverse-Effect-Level (NOAEL): 20,000 ppm.

Limited studies on HFC-236fa do not suggest developmental toxicity. Specific studies to evaluate the effect on female reproductive performance have not been conducted; however, limited information obtained from studies on developmental toxicity does not indicate adverse effects on female reproductive performance. Tests have shown that this material does not cause genetic damage in bacterial or mammalian cell cultures. No animal data are available to define carcinogenic effects of HFC-236fa.

ECOLOGICAL INFORMATION

Ecotoxicological Information**AQUATIC TOXICITY:**

96 hour LC50 – Zebra fish: 292 mg/l

96 hour LC50 – Freshwater algae: > 186 mg/l

48 hour LC50 – Daphnia magna: 299 mg/l

DISPOSAL CONSIDERATIONS

Waste Disposal

Treatment, storage, transportation and disposal must be carried out in accordance with applicable federal, state/provincial and local regulations.

TRANSPORTATION INFORMATION

OTHER INFORMATION

NFPA, NPCA-HMIS

NPCA-HMIS Rating

Health: 1

Flammability: 0

Reactivity: 1

The data in this Material Safety Data Sheet relate only to the specific material designated herein and do not relate to use in combination with any other material or in any process.

End of Material Safety Data Sheet

IX. WARRANTY

IX.1 Warranty Terms and Conditions

The producer grants to direct user a warranty for the period of 24 months from the date of purchase of the system. Liability of the company CONTEG, s.r.o. in case the company fails to repair system under this warranty even after reasonable number of attempts will be limited to obligation to replace the system – this replacement shall be the sole and exclusive remedial act for violating the warranty. Company CONTEG spol. S r.o. shall under no circumstances be responsible for any special, accidental or subsequent damages caused by violating the warranty, breaching the contractual relation or negligence. Such damages shall include lost profit, loss of product or related part, investment costs, costs for alternate equipment or replacement, downtimes or time of the purchaser, claims by third parties and damages to property. Warranty shall not apply to faults caused by external conditions as well as to mechanical damage caused by transport or those attributable to user. Warranty is void also in case the system is installed or used in conflict with instruction manual, assembly and commissioning instructions, and/or in case of faults caused by action of the user or possibly any other person without relevant authorization issued by the producer or failing to comply with requirements for operation stated in the instruction manual.

IX.2 Intellectual Property

CONTEG, spol. s r.o.

Na Vítězné pláni 1719/4, 140 00 Prague 4, Czech Republic



This documentation is protected by copyright. All related rights are reserved. Such rights cover in full or in part translations, copying, using images and diagrams, reproduction by photo-mechanical or other means and recording by data processing systems. The producer reserves the right to implement technical changes without prior notice.

IX.3 Statement of Compliance



Statement of Compliance

Producer: **CONTEG spol. s r.o.**

Address: **Na Vítězné pláni 1719/4**

140 00 Praha

Czech Republic

I hereby declare that the product fire alarm control panel LES-start-1 with integrated system of automatic fire detection and fire extinguishing unit filled with clean extinguishing agent HFC-236fa type:

LES-RACK-M and LES-RACK-S

complies with requirements of the below mentioned Directives of the European Parliament and of the Council as amended:

- EMC Directive 2004/108/EC
- LV Directive 2006/95/EC

Standards and technical regulations used as a ground for compliance assessment:
EN 61000-3, EN 61000-6, EN 50130-4, EN 55022-1, EN 60950-1

Related standards:
EN 60068-1, EN 60529, EN 60721-3-3, EN 54-7, EN ISO 228-1, ISO 7-1, EN ISO 9001, ISO 14520-11

I hereby as the producer declare that the product is safe provided that conditions for use mentioned above are observed. Simultaneously, we have adopted measures to ensure compliance of all products introduced to the market with technical documentation. Based on the above-mentioned, the system was marked by compliance mark **CE** in the year 2008.

In Prague, date May 23, 2016

.....
Vít Voláček
executive manager

IX.4 Certificate of Warranty

Certificate of Warranty

WARRANTY TERMS AND CONDITIONS

Customer is entitled to warranty services only against duly filled-in original of Certificate of Warranty or purchase payment receipt. Producer grants to consumer warranty for the period of 24 months commencing from the date of purchase stated in the Certificate of Warranty or purchase payment receipt. Warranty period will be prolonged by the period from accepting the product for repair to the date when the customer is obliged to collect the product. Warranty repairs, including description and duration, shall be confirmed in the Certificate of Warranty. Prior shipping from the factory, the product is duly checked and tested. It must be installed and used in compliance with the instruction manual. Claims shall be reported in writing and are conditioned by submitting duly filled-in Certificate of Warranty or purchase payment receipt and description of fault. Warranty is void if the product has been used in conflict with instruction manual, if data recorded in Certificate of Warranty or purchase payment receipt vary from those on product, or if the product cannot be identified by Certificate of Warranty or purchase payment receipt. Warranty is void if unauthorized person performed any action on the product or if its damage is attributable to external causes, such as dirt, improper use, unsuitable environment, force majeure or if due care for the product was neglected.

NOTICE TO CONSUMER

Upon accepting the product, however no later than before its installation, the consumer is obliged to make itself familiar with use and operation of the system as described in the instruction manual, check accuracy and legibility of data filled in the Certificate of Warranty and whether they match those on the product. Any claims thereafter cannot be considered.

System type: LES-RACK-S

PRODUCTION DATE	SERIAL NUMBER	CHECKED BY

RECORDS OF PURCHASE

DATE OF PURCHASE	VENDOR
FILL IN DAY, MONTH, YEAR	STAMP AND SIGNATURE

Warning: The author of this document, company CONTEG spol. s r.o., is trademark for the right to change the content without any previous notice.

This document is protected by copyright ©2016